

**SECTION X-X
SCALE 1 : 5**

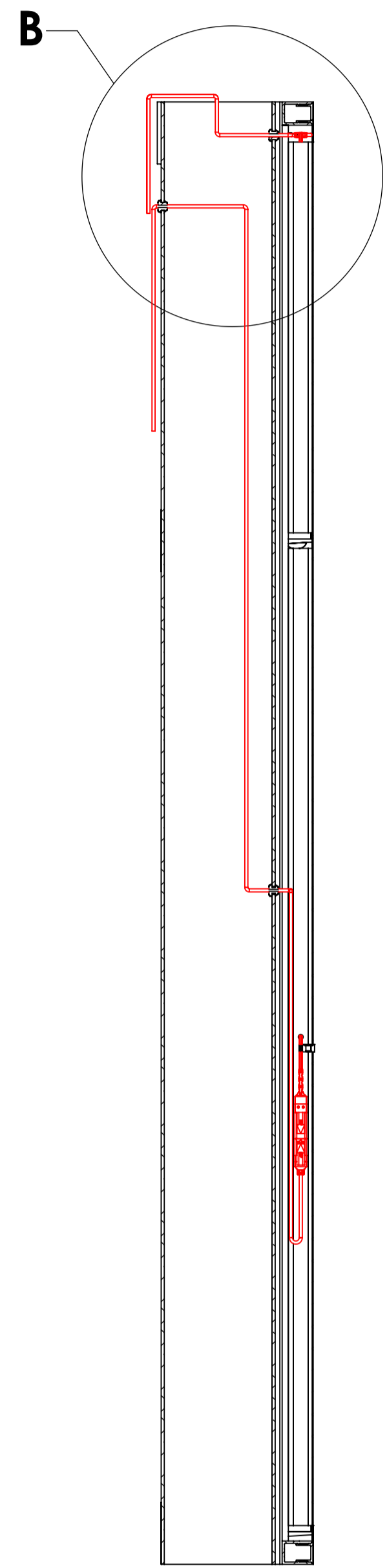

**SECTION Y-Y
SCALE 1 : 5**

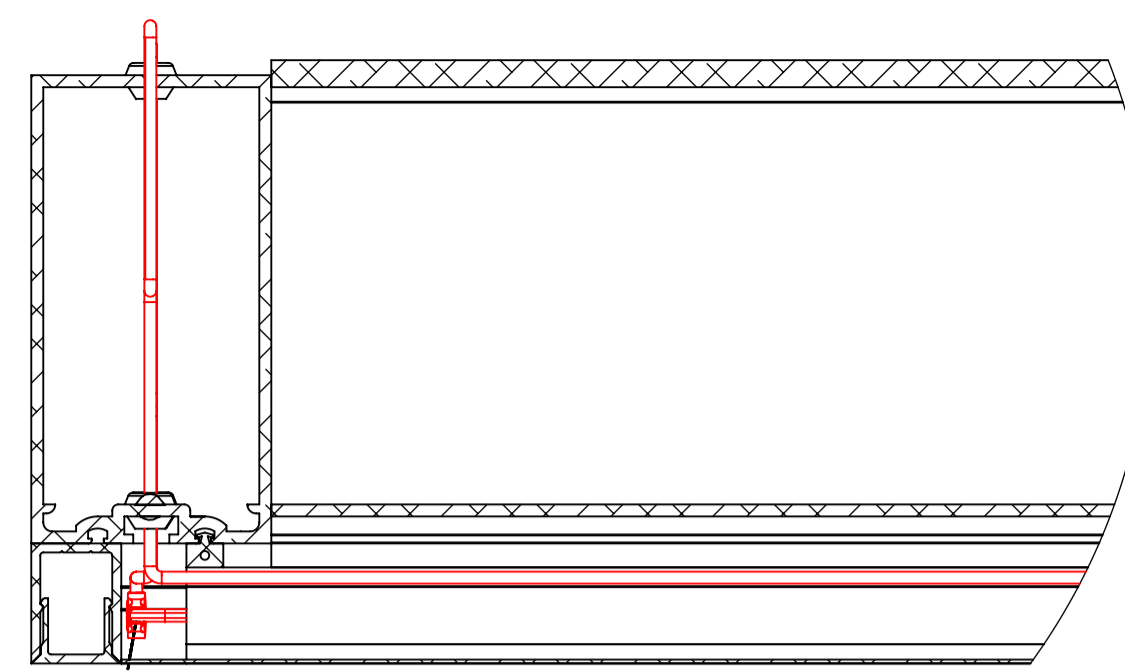
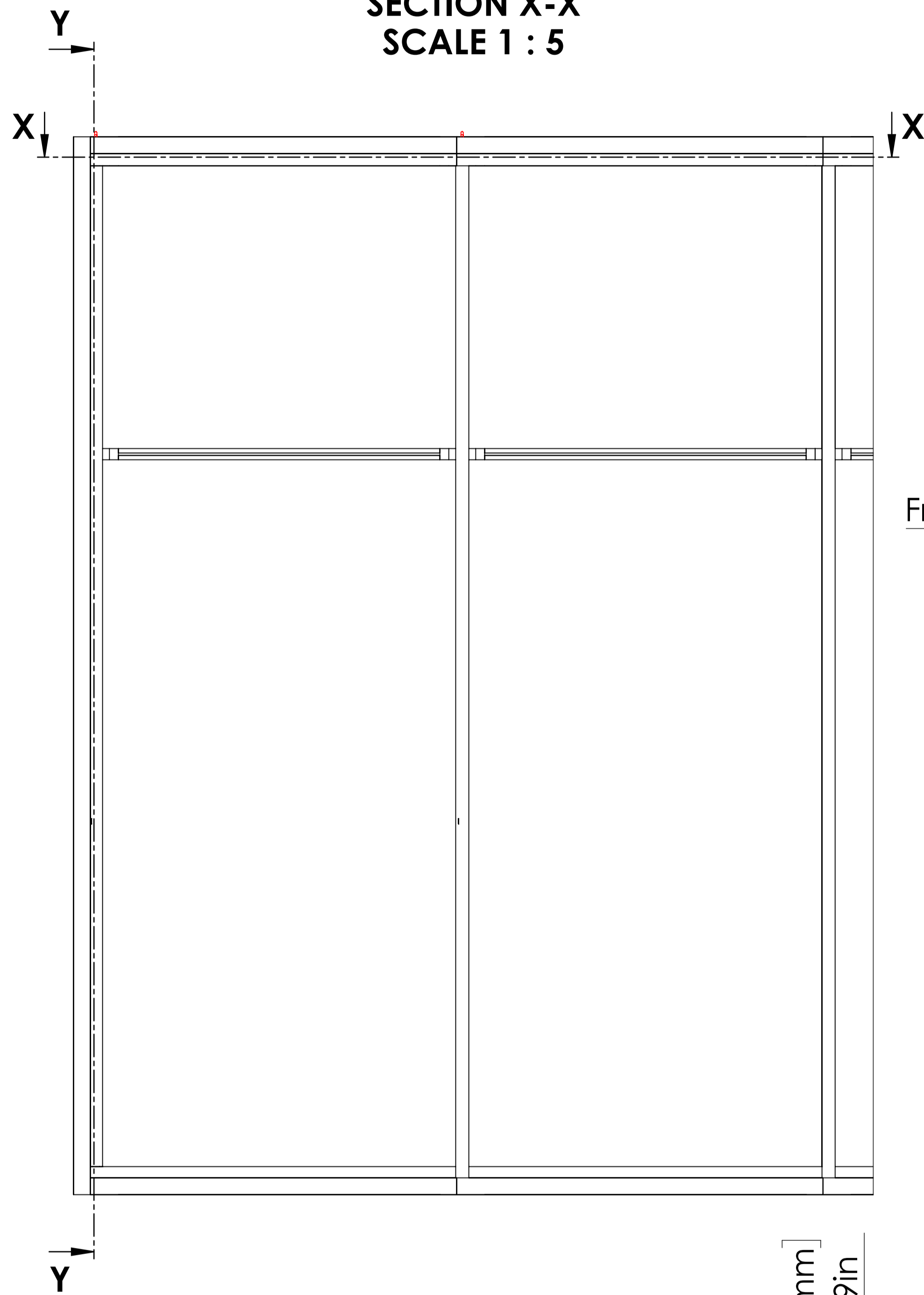

**DETAIL A
SCALE 1 : 2**

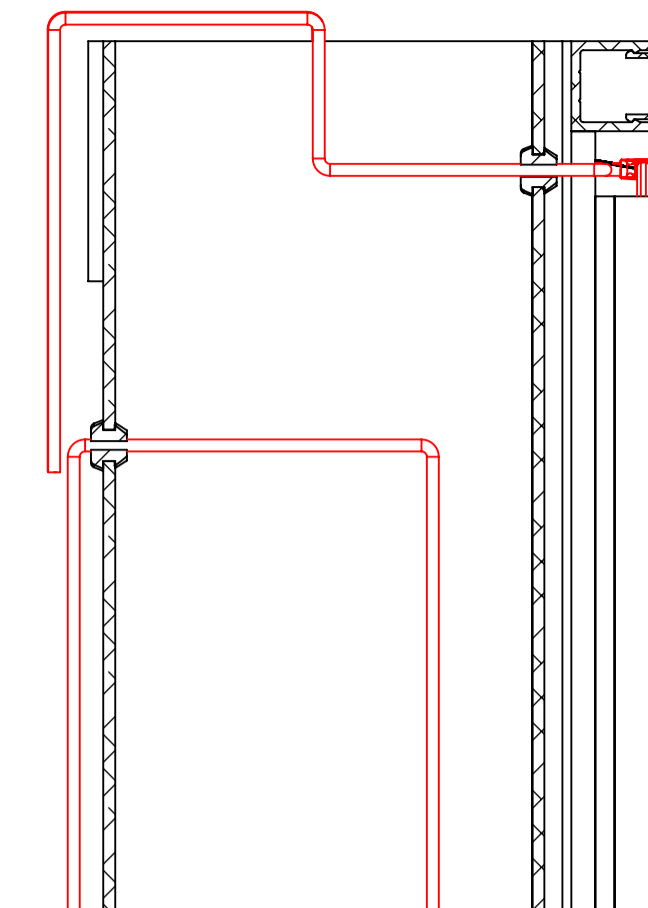

**DETAIL B
SCALE 1 : 2**

CONNECTOR ASSEMBLY

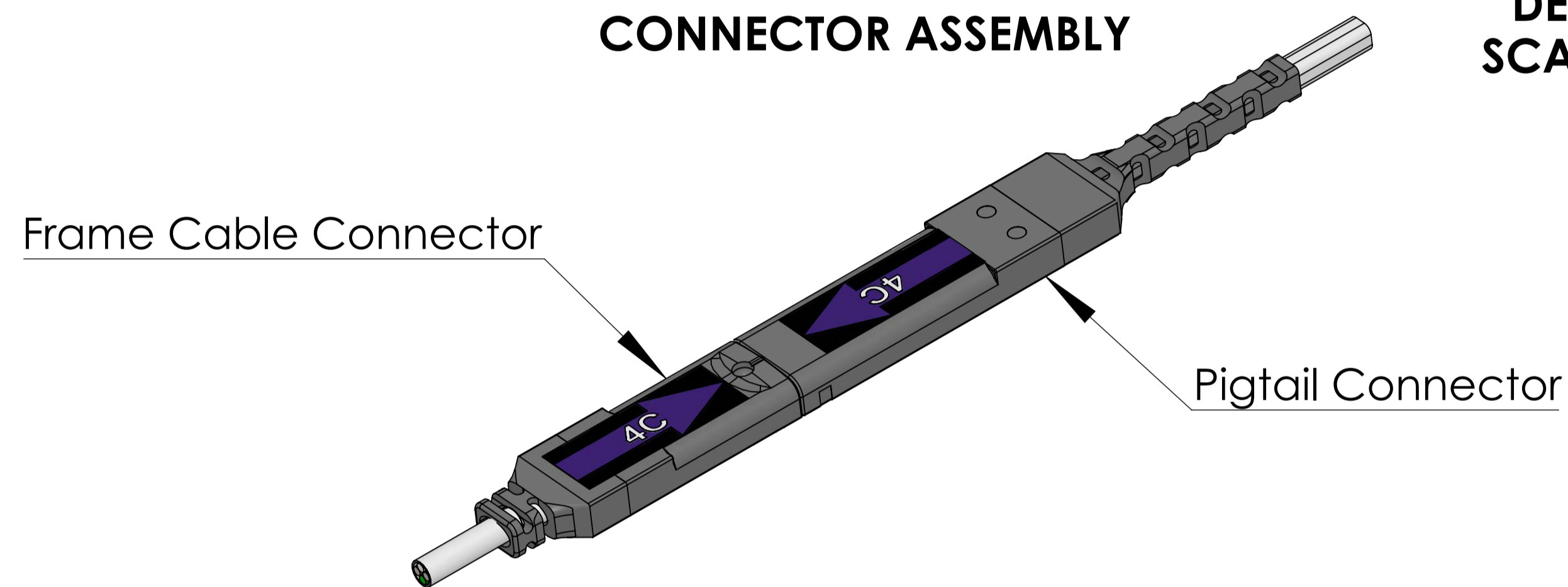

Recommended Steps for Installation:

1. Drill 10 mm hole for frame cable grommet.
2. De-bur hole using hand held file.
3. Utilize silicone Dow 795 or similar adhesive to secure grommet in hole.
4. Feed frame cable through the grommated hole with the connection point remaining in the glazing pocket. (SSG applications may require a cutout slot allowing the connection of the pigtail and frame cable to sit flush and not disrupt the smooth finish of the SSG).
5. If factory glazed, pigtail and frame cable are to be assembled inside the glazing pocket during the factory assembly of IGU and frame cable to be protected during transport and installation at site. Protect pigtail and frame cable at all times.
6. Glazier must label frame cable to match corresponding IGU per wiring diagram. If not enough room inside glazing pocket, bring the pigtail to frame cable connection out to a suitable location.
7. While installing glass, connect the pigtail to the frame cable and create a service loop in the glazing pocket.
8. Finish glazing ensuring none of the wires are pinched or damaged.
9. Cable bundled at the mullion exit to be protected.
10. Use the provided Field Wiring Tester after each frame cable is routed through the frame.
11. This drawing shows frame cable routing options, but other options may work as well or better. Service loop, protecting, testing, and labelling the frame cable is required.

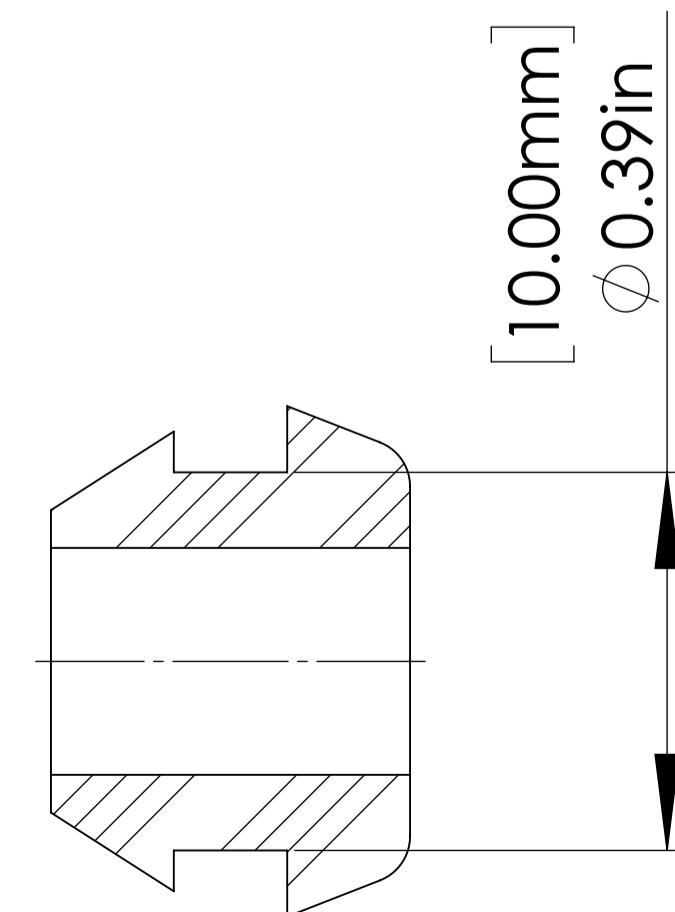
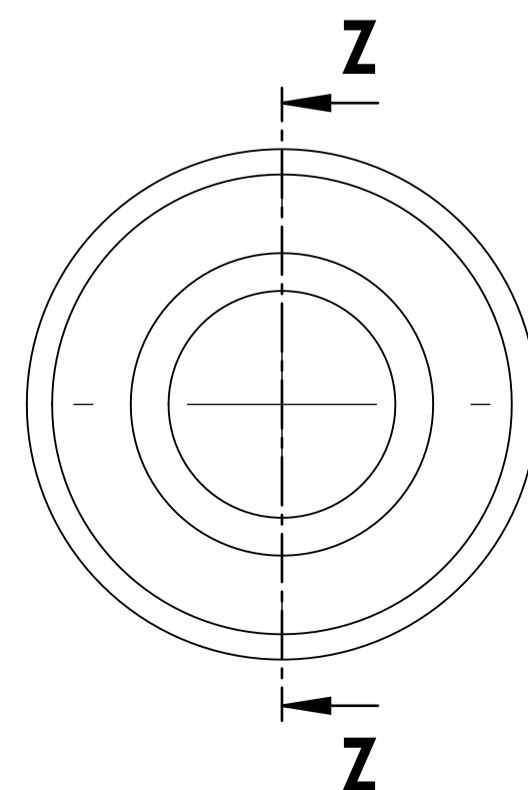
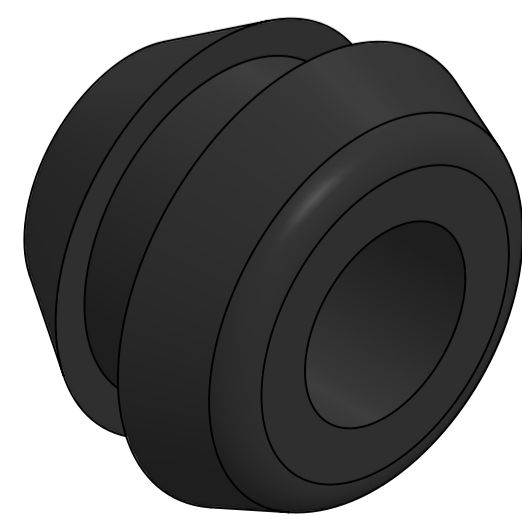

**SECTION Z-Z
SCALE 5 : 1**

OVERVIEW

		SAGE Electrochromics Inc.	
<small>ALL DIMENSIONS ARE IN "inches"</small>		DRAWING SHEET	A1
DRAWN BY	TSS	REVISION	APPROVED BY DATE
CHECKED BY			
DESCRIPTION :			
EFCO Series 5900 SSG			
SCALE: 1:8	DATE : 17-11-2022	SHEET NO	1 OF 7

ASSEMBLED FRAME

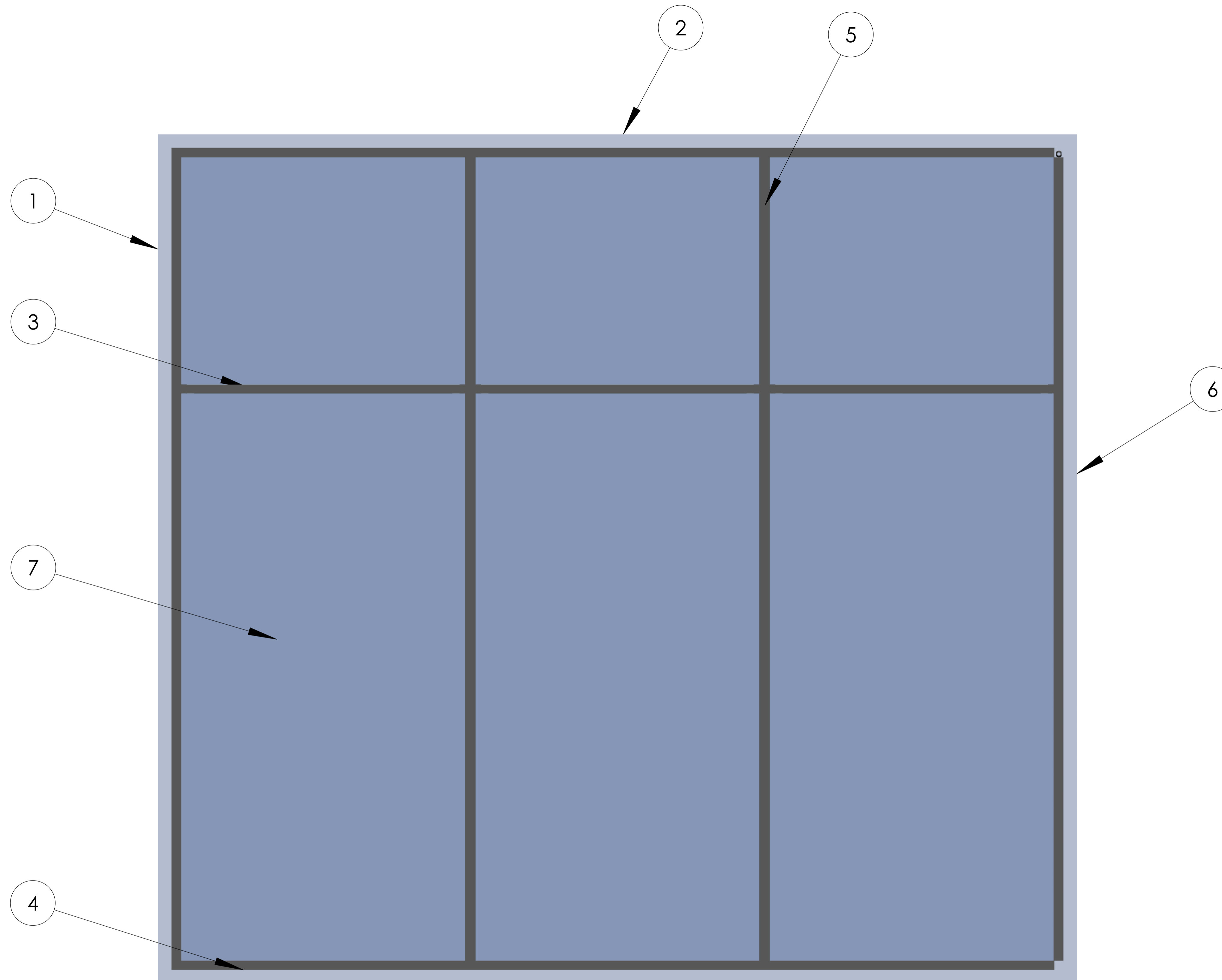

- ① - LEFT JAMB
- ② - HEAD
- ③ - HORIZONTAL
- ④ - SILL
- ⑤ - VERTICAL
- ⑥ - RIGHT JAMB
- ⑦ - SAGE GLASS

THIS DRAWING IS THE PROPERTY AND COPYRIGHT OF SAGE ELECTROCHROMICS INC. REPRODUCTION OR REUSE WITHOUT PERMISSION IS PROHIBITED. DO NOT SCALE THE DRAWING.

SAGE Electrochromics Inc.		DRAWING SHEET	A1
ALL DIMENSIONS ARE IN "inches"		REVISION	APPROVED BY DATE
DRAWN BY	TSS		
CHECKED BY			
DESCRIPTION :			
EFCO Series 5900 SSG			
SCALE: 1:5		DATE : 17-11-2022	
		SHEET NO	2 OF 7

CONNECTOR ASSEMBLY - VERTICAL MULLION

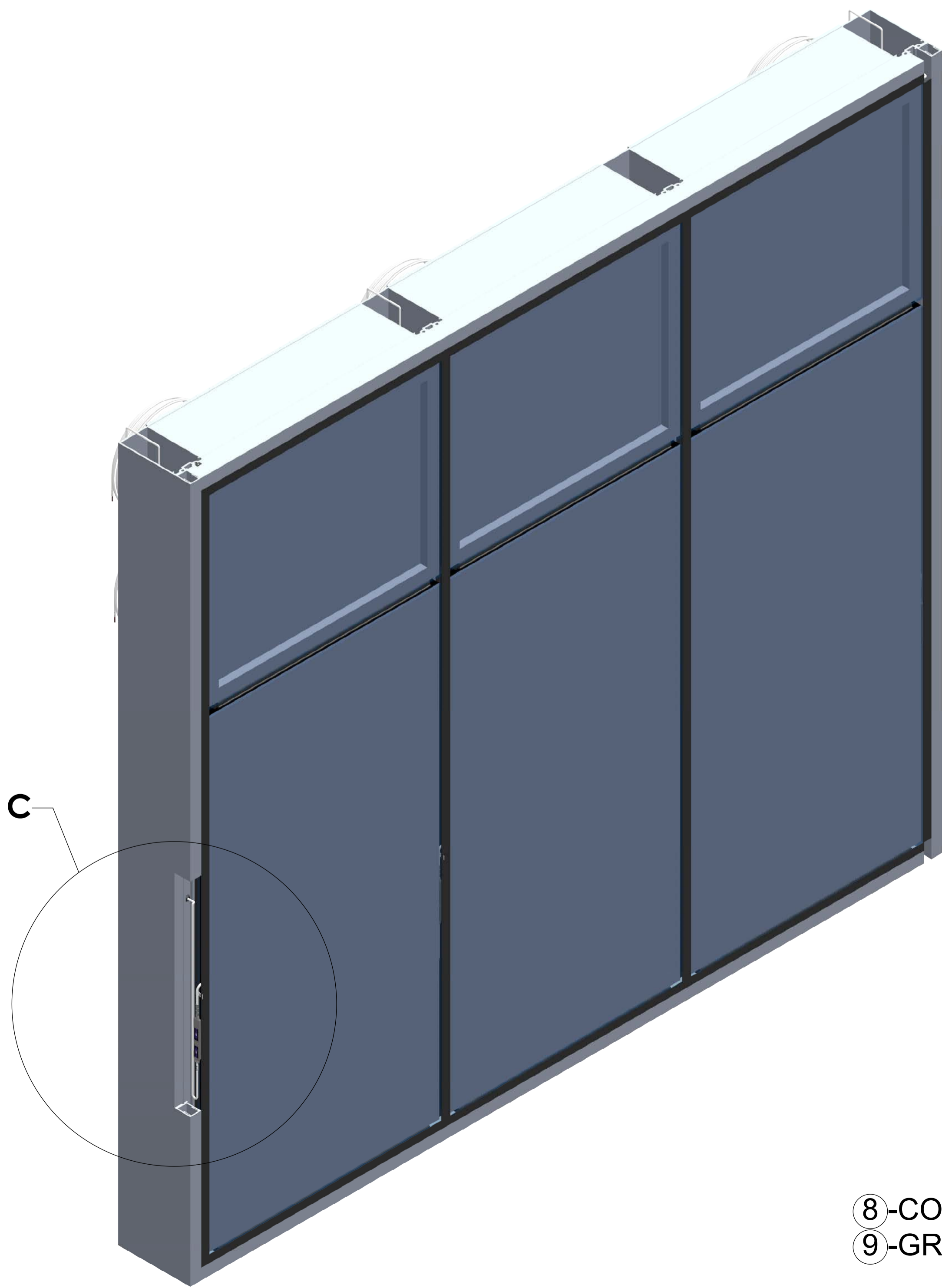

FRAME CABLE
EXITING THE
GLAZING POCKET
OF THE MULLION

CONNECTOR
ASSEMBLY INSIDE
GLAZING POCKET
OF VERTICAL
MULLION

8

9

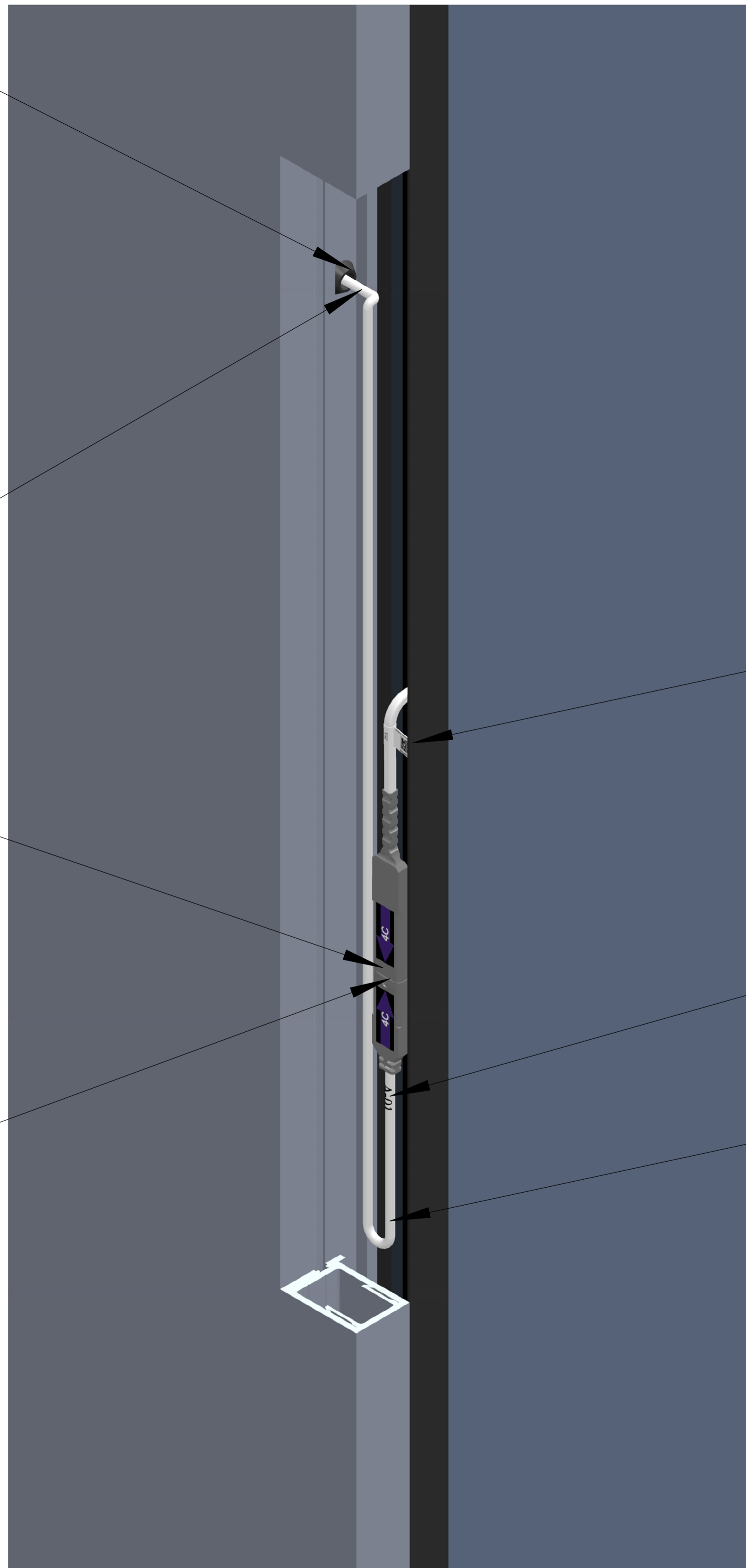

PIGTAIL LABEL

REFERENCE TAG

SERVICE LOOP

- ⑧-CONNECTOR ASSEMBLY
- ⑨-GROMMET

DETAIL C
SCALE 1 : 1

		SAGE Electrochromics Inc.	
ALL DIMENSIONS ARE IN "inches"		DRAWING SHEET	A1
DRAWN BY	TSS	REVISION	APPROVED BY DATE
CHECKED BY	[]	[]	[]
DESCRIPTION :			
EFCO Series 5900 SSG			
SCALE: 1:5	DATE: 17-11-2022	SHEET NO	3 OF 7

CONNECTOR ASSEMBLY - HORIZONTAL MULLION

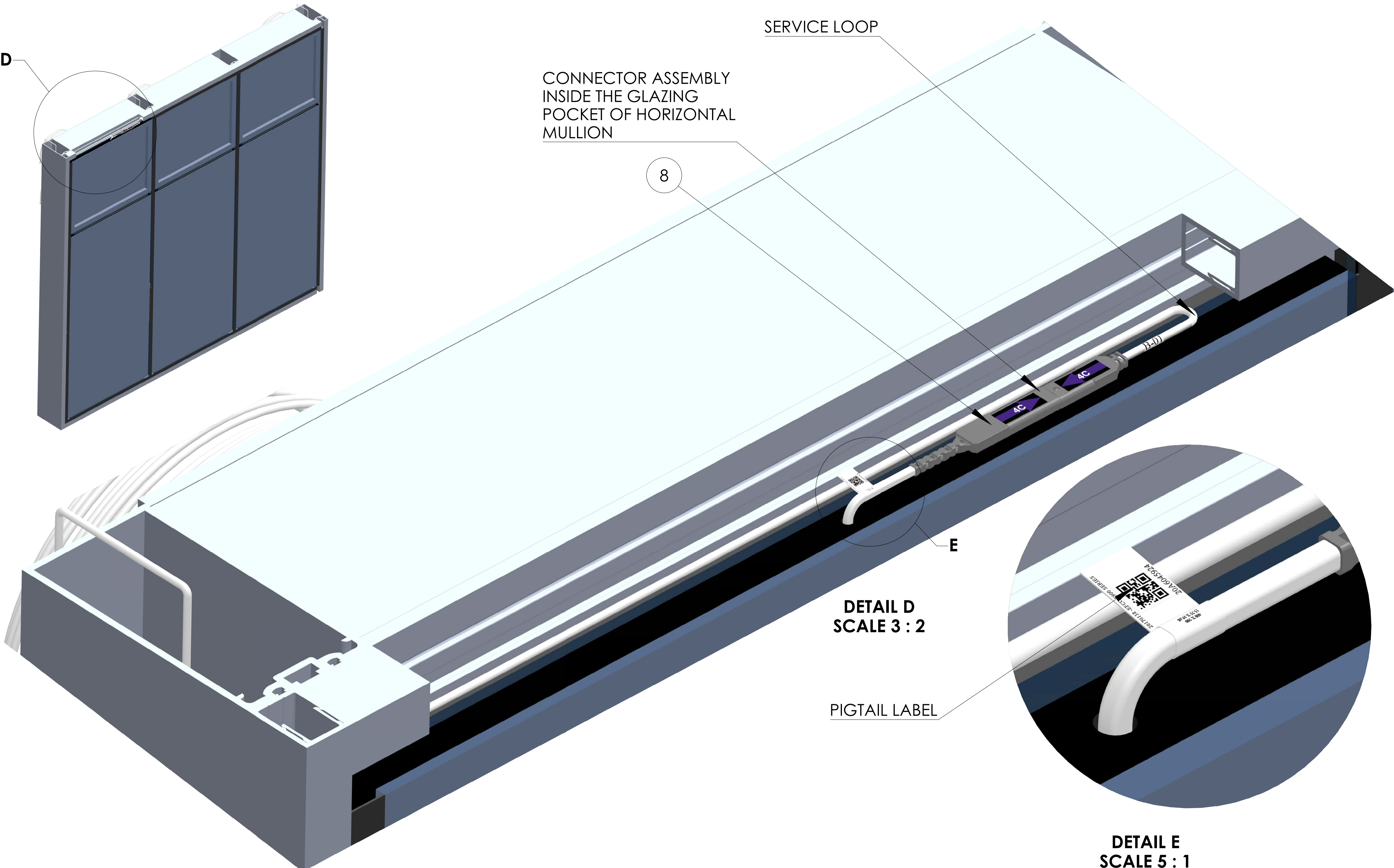

⑧ - CONNECTOR ASSEMBLY

		SAGE Electrochromics Inc.	
<small>ALL DIMENSIONS ARE IN "inches"</small>		DRAWING SHEET	A1
DRAWN BY	TSS	REVISION	APPROVED BY DATE
CHECKED BY			
DESCRIPTION :			
EFCO Series 5900 SSG			
SCALE: 1:6	DATE : 17-11-2022	SHEET NO	4 OF 7

FRAME CABLE ROUTING

PROTECT FRAME CABLE FROM SHARP EDGE OF MULLION

FRAME CABLE MAY EXIT MULLION THROUGH BACK AND OR THROUGH TOP

FRAME CABLES EXITING MULLION

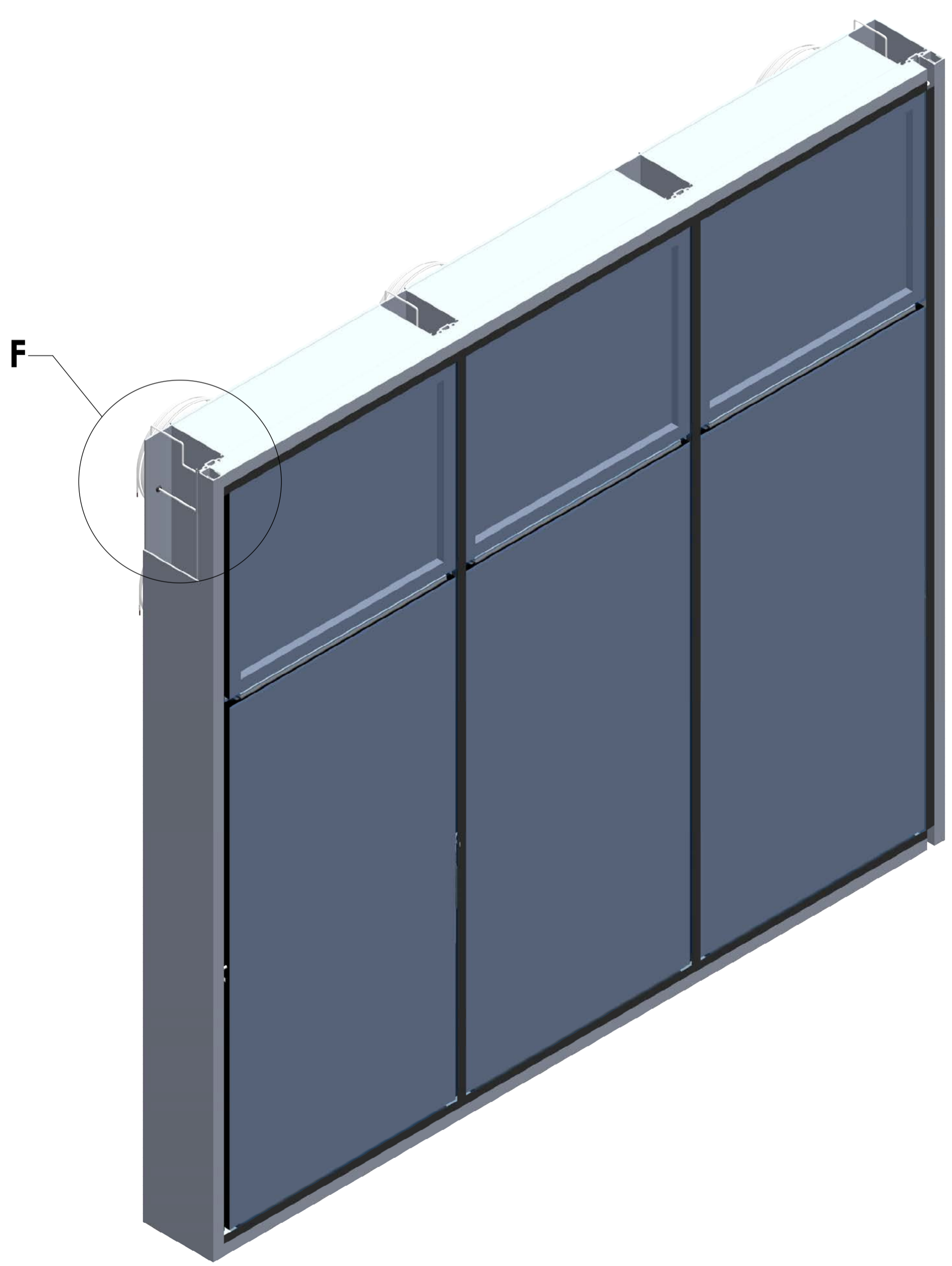

9

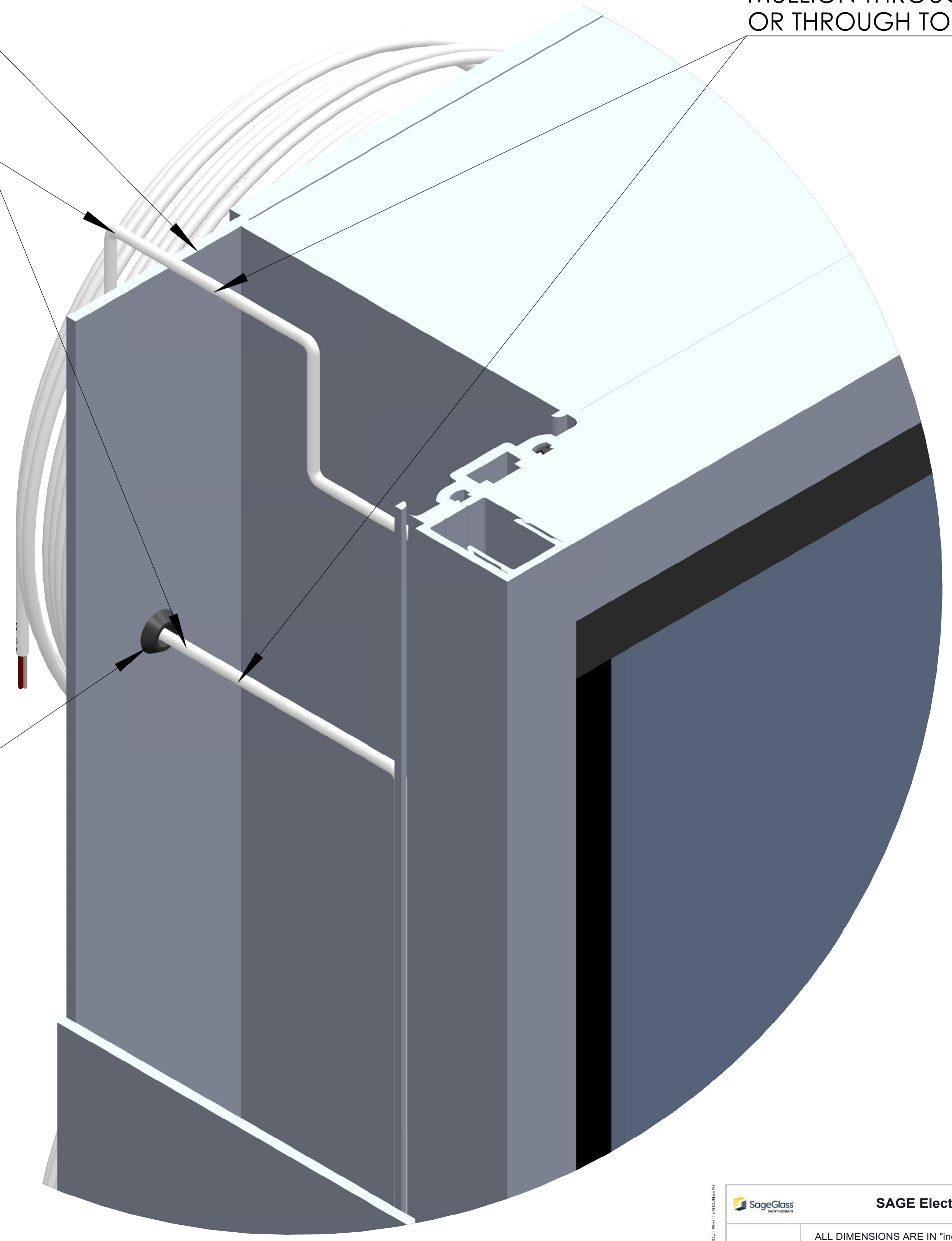

9 - GROMMET

DETAIL F
SCALE 3 : 2

SageGlass **SAGE Electrochromics Inc.**

ALL DIMENSIONS ARE IN "inches"

DESCRIPTION : **EFCO Series 5900 SSG**

SCALE: 1:6 DATE : 17-11-2022

DRAWN BY	TSS	REVISION	APPROVED BY DATE
CHECKED BY			

DRAWING SHEET A1

SHEET NO 5 OF 7

THIS DRAWING IS THE PROPERTY AND COPYRIGHT OF SAGE ELECTROCHROMICS INC. UNLESS OTHERWISE SPECIFIED, ALL DIMENSIONS ARE IN INCHES. REPRODUCTIONS OR USES WITHOUT PERMISSION DO NOT SCALE THE DRAWING.

FACTORY GLAZED FRAME and REF TAGS

PROTECT FRAME CABLE FROM SHARP EDGE OF MULLION

FRAME CABLES COILED, SECURED AND PROTECTED BEFORE AND DURING TRANSPORTATION TO SITE

FRAME CABLE MAY EXIT MULLION THROUGH BACK AND OR THROUGH TOP

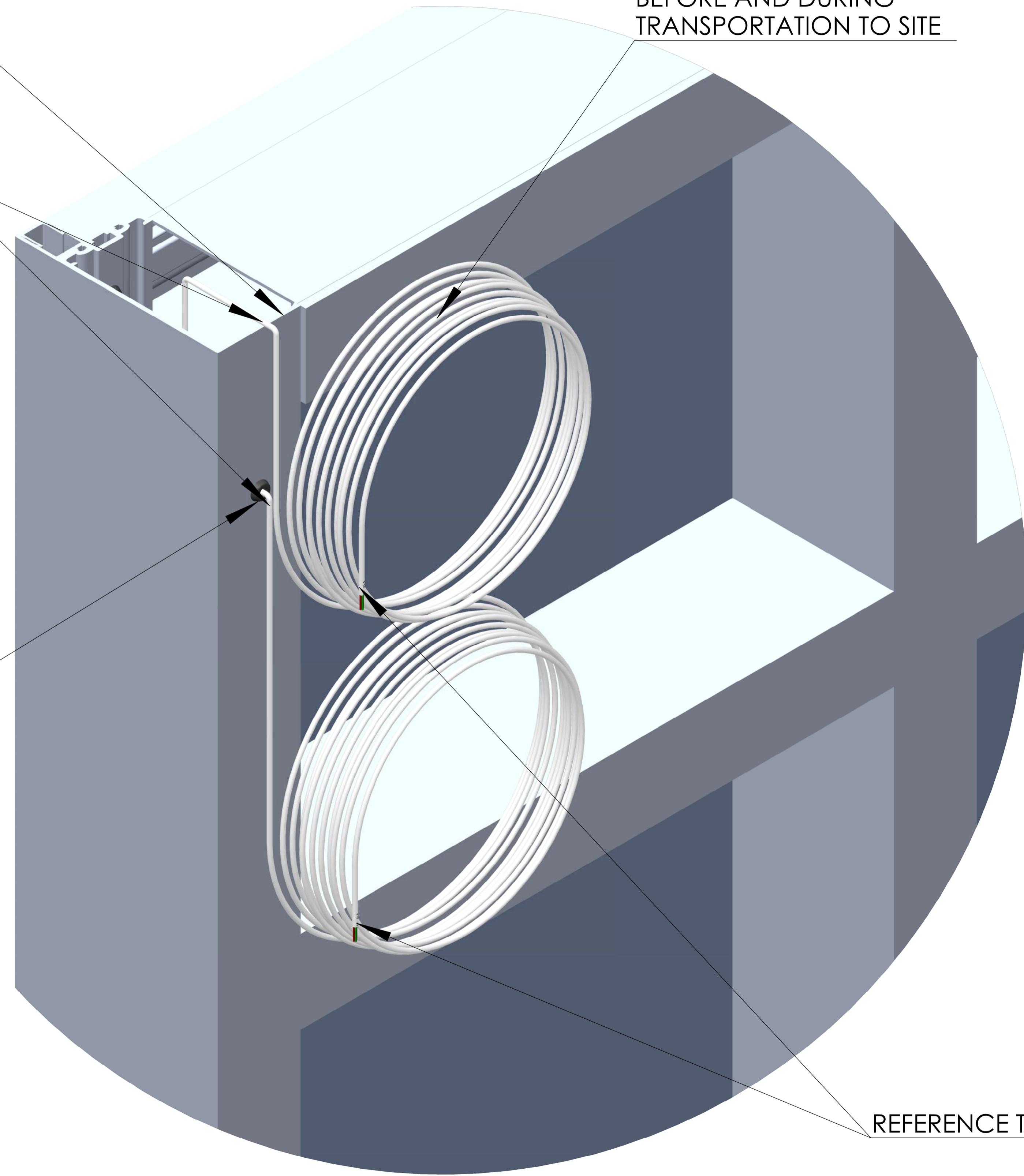
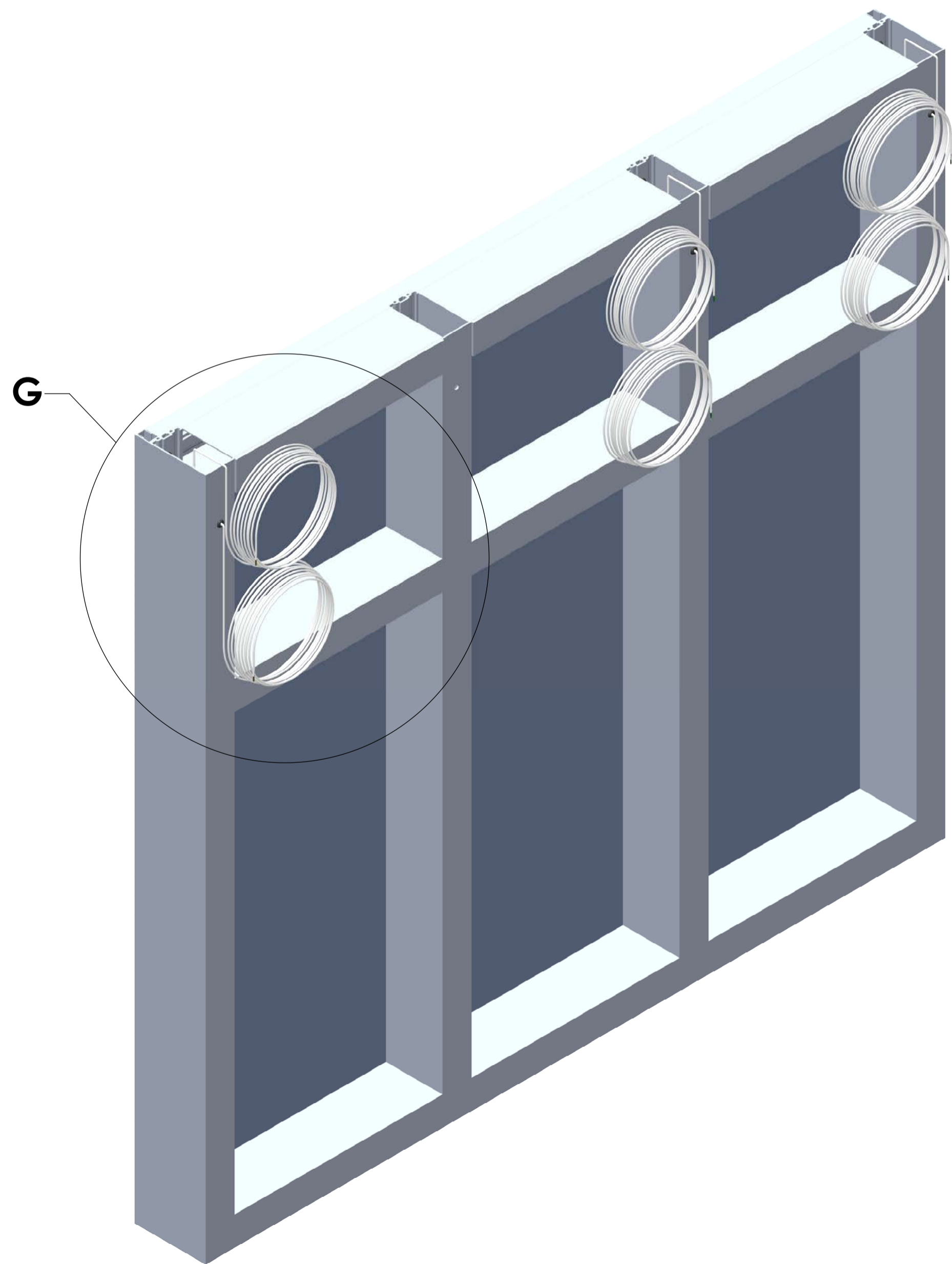

REFERENCE TAGS

⑨ - GROMMET

DETAIL G
SCALE 2 : 3

		SAGE Electrochromics Inc.	
ALL DIMENSIONS ARE IN "inches"		DRAWING SHEET	A1
DRAWN BY	TSS	REVISION	APPROVED BY DATE
CHECKED BY			
DESCRIPTION :			
EFCO Series 5900 SSG			
SCALE: 1:6	DATE : 17-11-2022	SHEET NO	6 OF 7

THIS DRAWING IS THE PROPERTY AND COPYRIGHT OF SAGE ELECTROCHROMICS INC. REPRODUCTION OR USE WITHOUT PERMISSION IS PROHIBITED. DO NOT SCALE THE DRAWING.

TEST SET UP FOR 4C FRAME CABLE

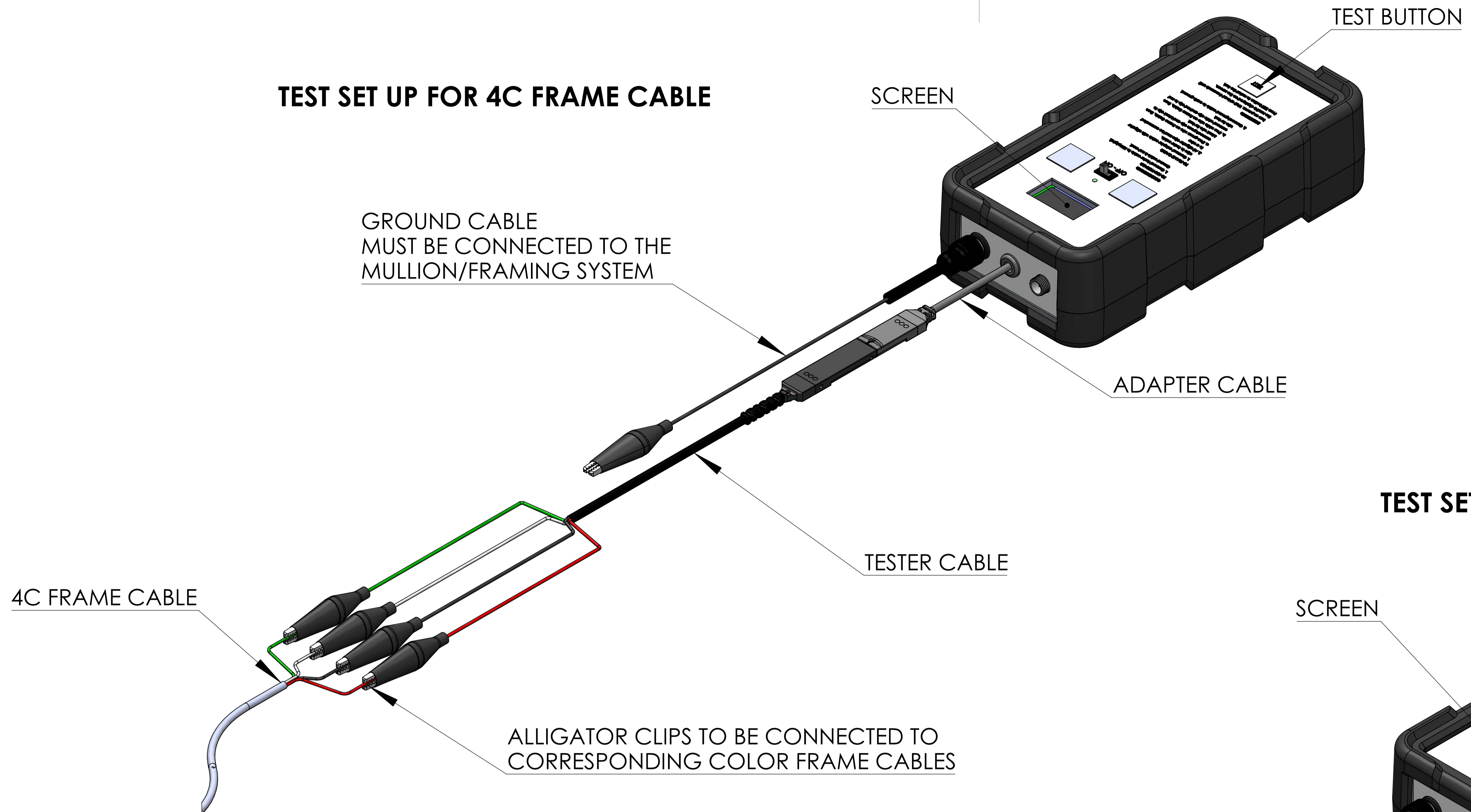

TEST SET UP FOR 2C FRAME CABLE

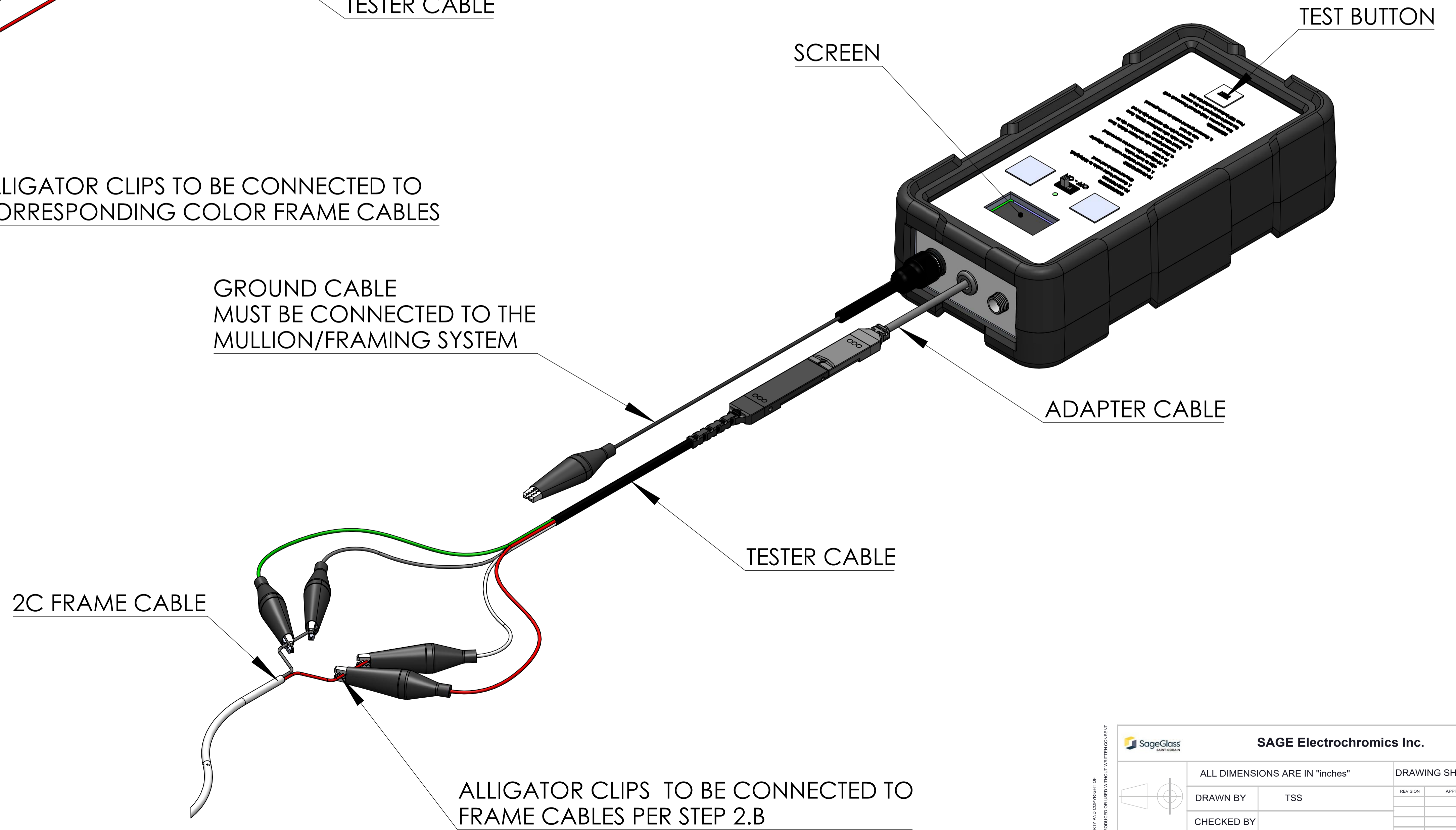

CONNECTIONS:

TO FRAME CABLE:

1. Connect adapter cable with alligator clips to tester cable.
2. All alligator clips must be connected to a wire:
 - a. If 4-Conductor frame cable, connect each alligator clip to the corresponding frame cable wire.
 - b. If 2-Conductor frame cable, connect red and white alligator clips to red frame cable wire and black and green alligator clips to black frame cable wire.
3. Connect ground cable to earth ground. (mullion / framing system)

TO IGU PIGTAILS:

1. Connect tester cable to IGU pigtail. Ground cable is not used.

DIRECTIONS:

Turn on power. Wait at least 5 seconds until the result is displayed on the screen. Press TEST button to restart the test.

SAGE Electrochromics Inc.		DRAWING SHEET	A1
ALL DIMENSIONS ARE IN "inches"		REVISION	APPROVED BY DATE
DRAWN BY	TSS		
CHECKED BY			
DESCRIPTION :			
EFCO Series 5900 SSG			
SCALE: 1:1	DATE: 17-11-2022	SHEET NO	7 OF 7